



SHUTTERS SPECIFICATION SHEET

CUSTOMWEST
THE SHUTTER SPECIALIST

RANGES

SEATTLE

Full Engineered Wood shutter

GEORGIA

Engineered Wood frames and panel with ABS louvres

BOSTON

Engineered Wood Frames with wood panels

MONTANA

Wood panels and frames

HOLLYWOOD

ABS / Water Resistant shutter

MOUNTING TYPES

FULL HEIGHT

A shutter panel that extends across the full height of the window opening.

TIER ON TIER

Two separate shutter panels that sit on top of each other and open independently – similar to a stable door.

TIER ON TIER WITH HORIZONTAL T POST

Two separate shutter panels that sit on top of horizontal T-post that sits between both tiers. Both upper & lower panels open independently – similar to a stable door. Please note specification limit for horizontal T-post is 1219mm and must be supported by a vertical T-post beneath after this width to stay within warranty.

CAFÉ

A shutter panel that typically only covers $\frac{1}{2}$ to $\frac{3}{4}$ of the window opening with a gap between the top of the recess and the shutter below.

BI-FOLD TRACK

A set of shutter panels mounted onto tracked runners which fold in pairs to one or both sides of the recess (see separate spec sheet re track).

BYPASS TRACK

A set of shutter panels mounted onto track runners which bypass each other – similar to wardrobe doors (see separate spec sheet re track).

L FRAMED TRACK

A set of shutter panels mounted onto track runners within an L frame. Note – only a maximum of LLRR can be provided without bottom track (see separate spec sheet re track).

STANDARD SPECIAL SHAPES

A non-rectangular shape that sizes can be determined by maths (IE triangles, perfect arches or circles, hexagons etc). See shaped section for which shapes are available in which ranges.

NON STANDARD SPECIAL SHAPES

A non-rectangular shape that does not follow any formulas regarding its measurements (i.e. uneven arches). Templates must be provided to the factory to show the shape of the curve required. NB – this mounting type option is only available in Montana range.



LOUVRE SIZE

47MM ELLIPTICAL LOUVRE



63MM ELLIPTICAL LOUVRE

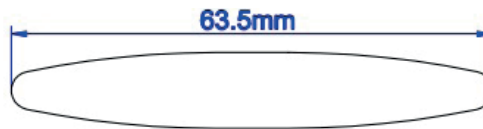

76MM ELLIPTICAL LOUVRE

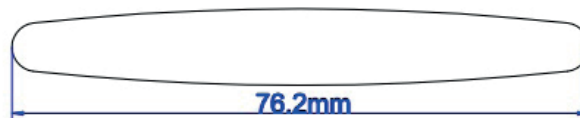

89MM ELLIPTICAL LOUVRE

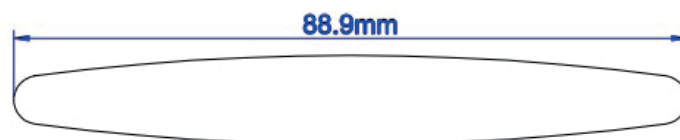

114MM ELLIPTICAL LOUVRE



- 114mm louvre is not available in Boston range
- 47mm louvre is not available with easy tilt
- Solid Panels (raised or based) are only available in Montana range

TILT ROD TYPES

All tilt rod types listed below are available in all shutter ranges.

CENTRAL TILT ROD

A tilt bar mounted in the centre of louvres which operate all louvres within a section at once.

OFFSET TILT ROD

A tilt bar mounted to one side of louvres which operate all louvres within a section at once. You can specify which side of the panel you would prefer the tilt rod to be on.

EASY TILT

A hidden tilt mechanism that is concealed within the side of the panel. Please note that above 1370mm – the easy tilt must be split to stay within warranty.

PANEL LIMITATIONS

SEATTLE

HINGED SHUTTER SPECIFICATION

Louvre size	Width				Height	
	Min.	Max			Min.	Max*
		Single Hung	Bi-fold	Multi-fold		
47mm	152mm	600mm	600mm	N/A	250mm	3000mm
63mm						
76mm		750mm				
89mm						
114mm						

TRACKED SHUTTER SPECIFICATION

Louvre size	Width			Height
	Min.	Max		Max*
		Top & Bottom Track	Top Track only	
47mm	152mm	600mm	N/A	3000mm
63mm				
76mm				
89mm				
114mm				

GEORGIA

HINGED SHUTTER SPECIFICATION

Louvre size	Width				Height	
	Min.	Max			Min.	Max*
		Single Hung	Bi-fold	Multi-fold		
47mm	152mm	610mm	610mm	N/A	250mm	3000mm
63mm						
76mm		915mm				
89mm						
114mm						

TRACKED SHUTTER SPECIFICATION

Louvre size	Width			Height
	Min.	Max		Max*
		Top & Bottom Track	Top Track only	
47mm	152mm	610mm	N/A on standard 660mm on Framed Track only	3000mm
63mm				
76mm				
89mm				
114mm				

PANEL LIMITATIONS

BOSTON						
HINGED SHUTTER SPECIFICATION						
Louvre size	Width				Height	
	Min.	Max			Min.	Max*
		Single Hung	Bi-fold	Multi-fold		
47mm	152mm	750mm	660mm	550mm	250mm	3000mm
63mm		890mm				
76mm						
89mm						
114mm						
TRACKED SHUTTER SPECIFICATION						
Louvre size	Width				Height	
	Min.	Top & Bottom Track		Top Track only		Max*
		Max				
47mm	152mm	660mm		550mm 660mm* *Framed Track only		3000mm
63mm						
76mm						
89mm						
114mm						
MONTANA						
HINGED SHUTTER SPECIFICATION						
Louvre size	Width				Height	
	Min.	Max			Min.	Max*
		Single Hung	Bi-fold	Multi-fold		
47mm	152mm	750mm	660mm	550mm	250mm	3000mm
63mm		890mm				
76mm		1047mm				
89mm						
114mm						
TRACKED SHUTTER SPECIFICATION						
Louvre size	Width				Height	
	Min.	Top & Bottom Track		Top Track only		Max*
		Max				
47mm	152mm	660mm		550mm 660mm* *Framed Track only		3000mm
63mm						
76mm						
89mm						
114mm						

NB1 – Please note minimum panel for solid panels is 174mm for 41.3mm stile

NB2 – Solid shutters require mid rail at 1219mm

PANEL LIMITATIONS

HOLLYWOOD						
HINGED SHUTTER SPECIFICATION						
Louvre size	Width				Height	
	Min.	Max			Min.	Max*
		Single Hung	Bi-fold	Multi-fold		
47mm	152mm	550mm	550mm	N/A	250mm	3000mm
63mm		800mm	610mm			
76mm		890mm				
89mm						
114mm						
TRACKED SHUTTER SPECIFICATION						
Louvre size	Width				Height	
	Min.	Max			Max*	
		Top & Bottom Track	Top Track only			
47mm	152mm	660mm	N/A		3000mm	
63mm						
76mm						
89mm						
114mm						

Please note that specification limit for horizontal T-post is 1219mm and must be supported by a vertical T-post beneath after this width to stay within warranty.



COLOURS CHECK SHEET

		SEATTLE	GEORGIA	BOSTON	MONTANA	HOLLYWOOD
PAINTED COLOURS	001 Pure White	✓	✓	✓	✓	✓
	002 Extra white	✓	✓	✓	✓	✓
	003 Silk White	✓	✓	✓	✓	✓
	004 Vellum	-	✓	✓	✓	✓
	006 Pearl	✓	✓	✓	✓	✓
	007 Ivory Lace	-	✓	✓	✓	✓
	012 Crisp Linen	-	✓	✓	✓	✓
	013 Bisque	-	✓	✓	✓	✓
	019 String	-	✓	✓	✓	✓
	032 Sea Mist	✓	✓	✓	✓	✓
	042 Hall Gray	-	✓	✓	✓	✓
	045 Elephants Air	-	✓	✓	✓	✓
	046 Ice	-	✓	✓	✓	✓
	049 Stone Grey	-	✓	✓	✓	✓
	053 Clay	-	✓	✓	✓	✓
	063 Decorators White	✓	✓	✓	✓	✓
	076 Aura White	-	✓	✓	✓	✓
	080 Taupe Grey	-	✓	✓	✓	✓
Custom Colour	-	✓	✓	✓	✓	
STAINED COLOURS	108 Rustic Grey	-	-	-	✓	-
	109 Weathered Teak	-	-	-	✓	-
	110 Limed White	-	-	-	✓	-
	114 Taupe	-	-	-	✓	-
	202 Golden Oak	-	-	-	✓	-
	204 Oak Mantel	-	-	-	✓	-
	205 Medium Oak	-	-	-	✓	-
	211 Medium Cherry	-	-	-	✓	-
	219 Mahogany	-	-	-	✓	-
	221 Black Walnut	-	-	-	✓	-
	227 Red Oak	-	-	-	✓	-
	229 Rich Walnut	-	-	-	✓	-
	230 Old Teak	-	-	-	✓	-
	232 Red Mahogany	-	-	-	✓	-
	233 Dark Mahogany	-	-	-	✓	-
	237 Wenge	-	-	-	✓	-
	862 French Oak	-	-	-	✓	-
	1003 Osmo Matt White	-	-	-	✓	-
	1107 Osmo Antique Oak	-	-	-	✓	-
	1114 Weathered Grey	-	-	-	✓	-
1203 Osmo Rustic Black	-	-	-	✓	-	
1301 Osmo Cherry	-	-	-	✓	-	
1501 Osmo Oak	-	-	-	✓	-	

HARDWARE

	SEATTLE	GEORGIA	BOSTON	MONTANA	HOLLYWOOD
White	✓	✓	✓	✓	-
Pure White	✓	✓	✓	✓	-
Pearl	✓	✓	✓	✓	-
Bisque	✓	✓	✓	✓	-
Black	✓	✓	✓	✓	-
Sea Mist	✓	✓	✓	✓	-
Crisp Linen	✓	✓	✓	✓	-
Brown Grey	✓	✓	✓	✓	-
Stainless Steel	✓	✓	✓	✓	✓
Bright Brass	✓	✓	✓	✓	-
Antique Brass	✓	✓	✓	✓	-
Nickel	✓	✓	✓	✓	-
Brushed Nickel	✓	✓	✓	✓	-
Taupe Grey	✓	✓	✓	✓	-
String	✓	✓	✓	✓	-
Stone Grey	✓	✓	✓	✓	-

Concealed hinge is available with Georgia, Boston & Montana ranges and incurs a 10 % surcharge.
This hinge type is only available with the following frames:

	SEATTLE	GEORGIA	BOSTON	MONTANA	HOLLYWOOD
Camber Deco Frame 50mm	-	✓	✓	✓	-
Serrate Z Frame 50mm	-	✓	✓	✓	-
Bullnose Z Frame 50mm	-	✓	✓	✓	-
Bullnose Z Frame 50mm w/ 6mm Light Block	-	-	-	✓	-
Deep Bullnose Z Frame 38mm	-	✓	✓	✓	-
Beaded L Frame 46mm	-	✓	✓	✓	-
Beaded L Frame 60mm	-	✓	✓	✓	-
Beaded L Frame 76mm	-	✓	✓	✓	-
Deep Plain L Frame 60mm	-	✓	✓	✓	-
Chamfer T-post	-	✓	✓	✓	-
Chamfer T-post Deco	-	✓	✓	✓	-
Corner Post	-	✓	✓	✓	-
Corner Post Deco	-	✓	✓	✓	-
Bay Post	-	✓	✓	✓	-
Bay Post Deco	-	✓	✓	✓	-

Please note panel configuration is limited to single panels when using concealed hinge.
Multi fold configurations are not available even when warranty waived.

MOUNTING TYPE AVAILABILITY

	SEATTLE	GEORGIA	BOSTON	MONTANA	HOLLYWOOD
Full Height	✓	✓	✓	✓	✓
Tier on Tier	✓*	✓*	✓	✓	✓
Tier on Tier w/ Horizontal T Post	✓*	✓*	✓	✓	-
Café	✓	✓	✓	✓	✓
Shutter & Shade	-*	✓	✓	✓	-
Bi-fold Track Inside Mount (w/ Bottom Track)	✓	✓	✓	✓	✓
Bi-fold Track Inside Mount (Top Track Only)	-	-	✓	✓	-
Bi-fold Track Outside Mount (w/ Bottom Track)	✓	✓	✓	✓	-
Bi-fold Track Outside Mount (Top Track Only)	-	-	✓	✓	-
Bi-fold Track Semi Inside Mount (w/ Bottom Track)	✓	✓	✓	✓	✓
Bi-fold Track Semi Inside Mount (Top Track Only)	-	-	✓	✓	-
Bypass Track Inside Mount (w/ Bottom Track)	-	✓	✓	✓	✓
Bypass Track Inside Mount (Top Track Only)	-	-	✓	✓	-
Bypass Track Semi Inside Mount (w/ Bottom Track)	-	✓	✓	✓	✓
Bypass Track Semi Inside Mount (Top Track Only)	-	-	✓	✓	-
L Framed Track**	✓	✓	✓	✓	-
Standard Special Shapes	-	✓	✓	✓	✓
Non Standard Special Shapes	-	-	-	✓	-
French Cut Out	-	-	-	✓	-

*Tier on Tier is limited to 2 panels within warranty in Seattle & Georgia

**A maximum of 2 panels per side in any range can be provided without bottom track

***Bottom Track is mandatory for a panel fold of 4+ panels per side

**** Shutter & Shade is only available in the Seattle range in 001 Pure White and 003 Silk White colourways.

FRAMES

		SEATTLE	GEORGIA	BOSTON	MONTANA	HOLLYWOOD
L FRAMES	Vintage L Frame 32mm	-	-	-	-	✓
	Vintage L Frame 46mm	✓	✓	✓	✓	✓
	Vintage L Frame 60mm	✓	✓	✓	✓	✓
	Vintage L Frame 76mm	✓	✓	✓	✓	-
	Beaded L Frame 46mm	✓	✓	✓	✓	✓
	Beaded L Frame 60mm	✓	✓	✓	✓	✓
	Beaded L Frame 76mm	✓	✓	✓	✓	-
	Deep Plain L Frame 60mm	✓	✓	✓	✓	✓
	Plain L Frame 46mm	✓	✓	✓	✓	-
	Double Insert L Frame 50mm	✓	✓	-	-	-
	Double Insert L Frame 60mm	✓	✓	-	-	-
Z FRAMES	Deep Bullnose Z Frame 38mm	✓	✓	✓	✓	✓
	Bullnose Z Frame 50mm	✓	✓	✓	✓	-
	Bullnose Z Frame 50mm w/ 6mm Light Block (supplied w/ ball catches)	-	-	-	✓	-
	Serrate Z Frame 50mm	✓	✓	✓	✓	-
	Crown Z Frame 76mm	✓	✓	✓	✓	✓
	Tiara Z Frame 50mm	-	-	-	-	✓
	Bullnose Z Frame 38mm	-	-	-	-	✓

FRAMES

		SEATTLE	GEORGIA	BOSTON	MONTANA	HOLLYWOOD
DECO FRAMES	Camber Deco Frame 50mm (no insert in Hollywood)	✓	✓	✓	✓	✓
	Chamfer T-post Deco 32mm	✓	✓	✓	✓	✓
POST TYPES (BAY / CORNER / T-POSTS)	Chamfer T-post 46mm	✓	✓	✓	✓	✓
	Chamfer T-post 60mm	✓	✓	✓	✓	-
	T-post with Insert 46mm	✓	✓	✓	✓	-
	T-post with Insert 60mm	✓	✓	✓	✓	-
	T-post with Insert 76mm	✓	✓	✓	✓	-
	Beaded T-post Deco 32mm	-	-	-	-	✓
	Beaded T-post 46mm	-	-	-	-	✓
	Bay Post Deco 32mm	✓	✓	✓	✓	✓
	Bay Post	✓	✓	✓	✓	✓
	Bay Post with Insert Deco (135 degrees only)	✓	✓	✓	✓	-
	Bay Post with Insert (135 degrees only)	✓	✓	✓	✓	-
	Corner Post Deco (32mm)	✓	✓	✓	✓	✓
	Corner Post	✓	✓	✓	✓	✓

L FRAME DIMENSIONS

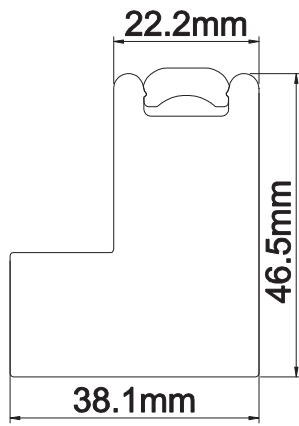

VINTAGE L FRAME 46MM

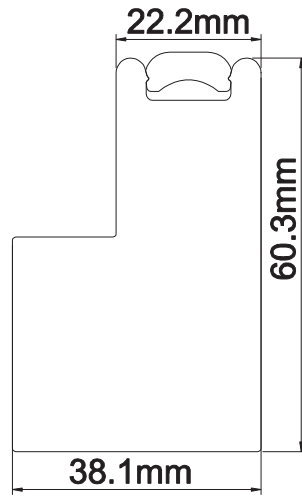

VINTAGE L FRAME 60MM

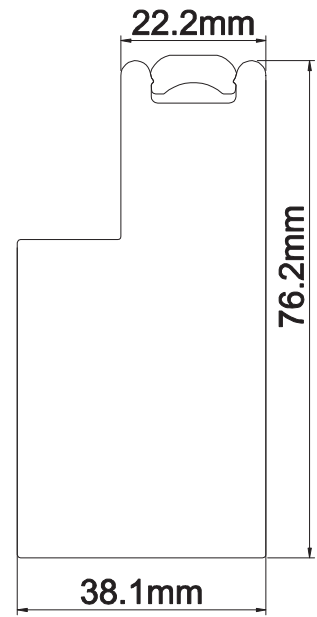

VINTAGE L FRAME 76MM

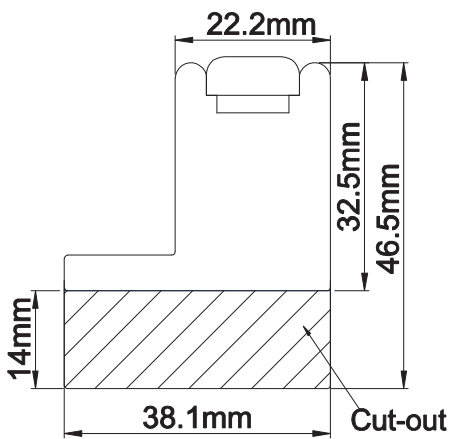

VINTAGE L FRAME 32MM

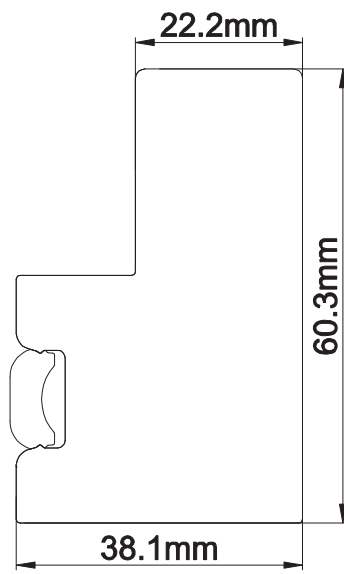

DEEP PLAIN L FRAME 60MM

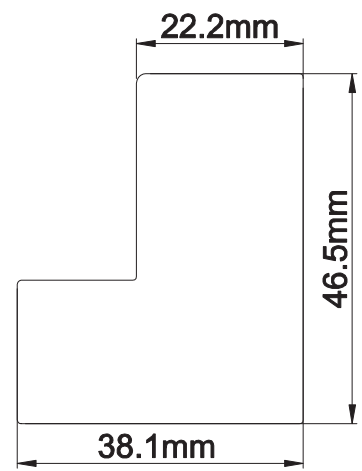

PLAIN L FRAME 46MM /SERRATE Z
SILL PLATE

L FRAME DIMENSIONS

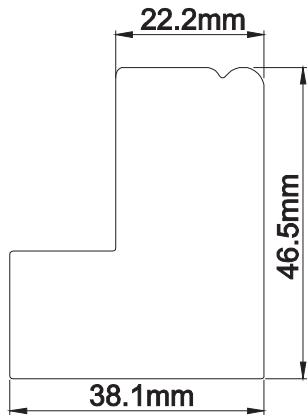

BEADED L FRAME 46MM

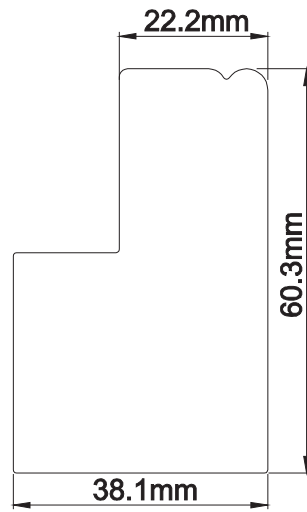

BEADED L FRAME 60MM

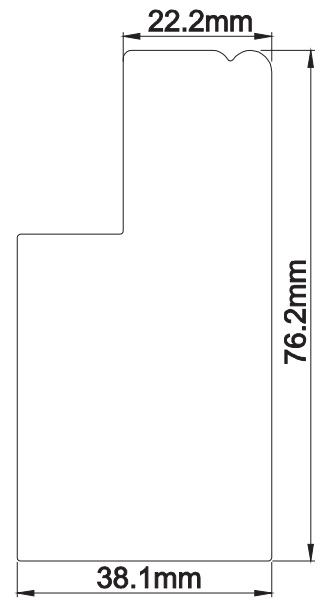

BEADED L FRAME 76MM

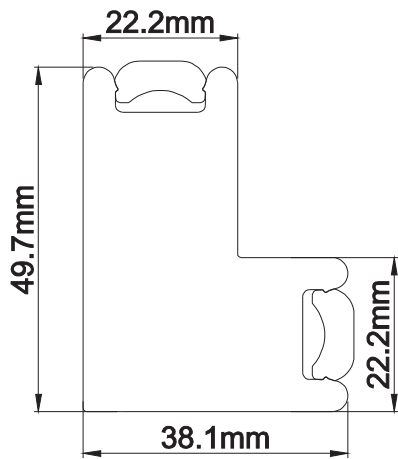

DOUBLE INSERT L FRAME 50MM

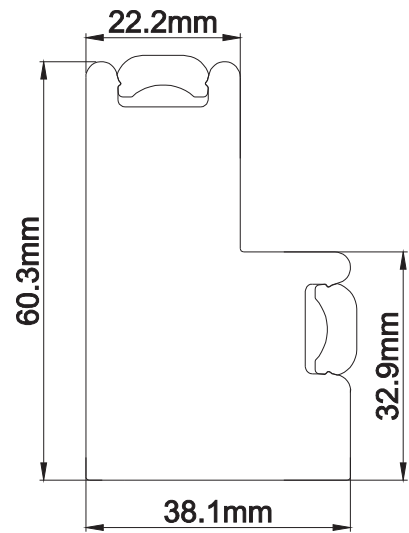

DOUBLE INSERT L FRAME 60MM

Z FRAME DIMENSIONS

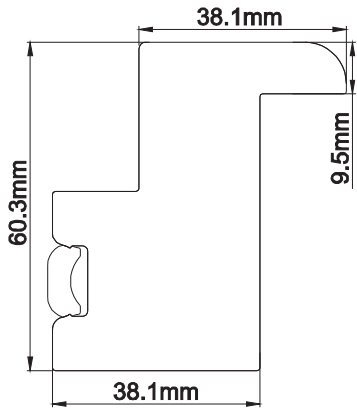

DEEP BULLNOSE Z FRAME 38MM

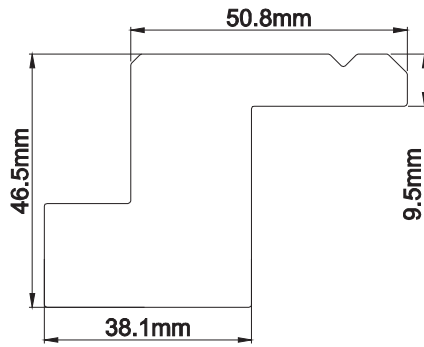

SERRATE Z FRAME 50MM

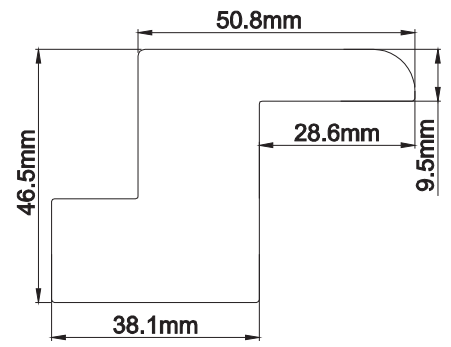

BULLNOSE Z FRAME 50MM

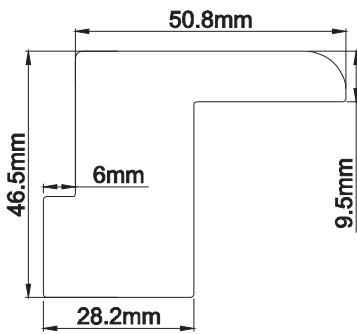

BULLNOSE Z FRAME 50MM WITH 6MM LIGHT BLOCK

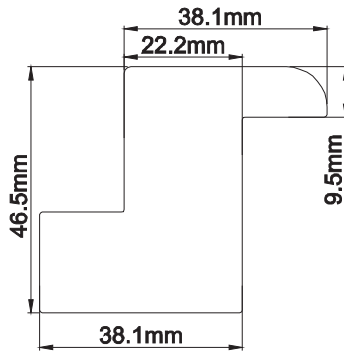

BULLNOSE Z FRAME 38MM

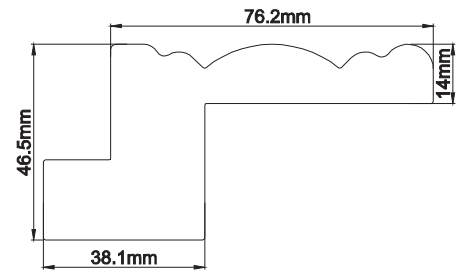

CROWN Z FRAME 76MM

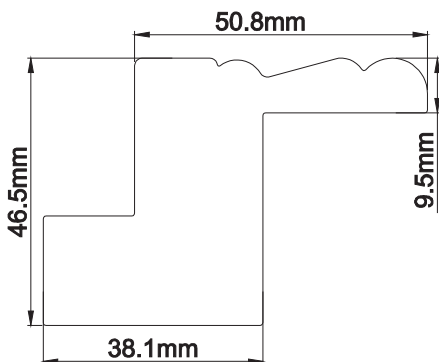

TIARA Z FRAME 50MM

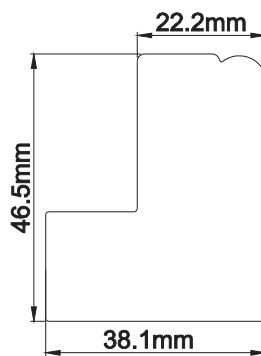

TIARA Z SILL PLATE

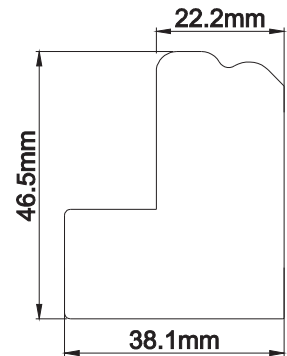

CROWN Z SILL PLATE

Please note that deep plain L Frame 60mm will be used as sill plate for deep bullnose Z Frame 38mm.

DECO FRAMES

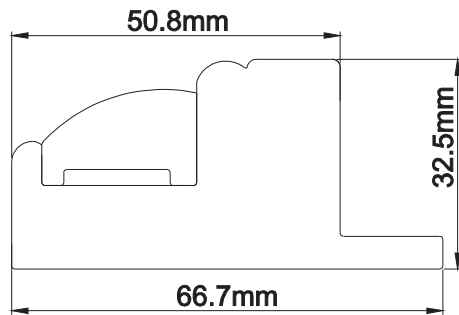

CAMBER DECO FRAME 50MM

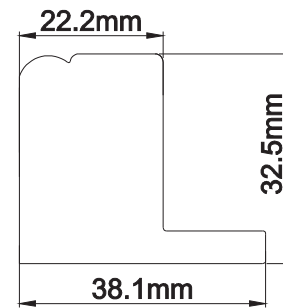

CAMBER DECO SILL PLATE

POSTS

	SEATTLE	GEORGIA	BOSTON	MONTANA	HOLLYWOOD
Corner Post	✓	✓	✓	✓	✓
Deco Corner Post	✓	✓	✓	✓	✓
Bay Post	✓	✓	✓	✓	✓
Deco Bay Post	✓	✓	✓	✓	✓
Bay Post with Insert	✓	✓	✓	✓	-
Deco Bay Post with Insert	✓	✓	✓	✓	-
Chamfer T-post	✓	✓	✓	✓	✓
Deco Chamfer T-post	✓	✓	✓	✓	✓
Beaded T-post	✓	✓	✓	✓	✓
Deco Beaded T-post	✓	✓	✓	✓	✓
T-post with Insert	✓	✓	✓	✓	-

*NB Bay posts with Inserts are only available for 135 degree angle.

POSTS

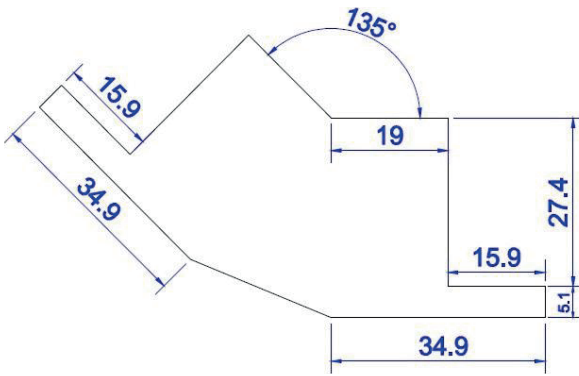

BAY POST FOR DECO FRAME

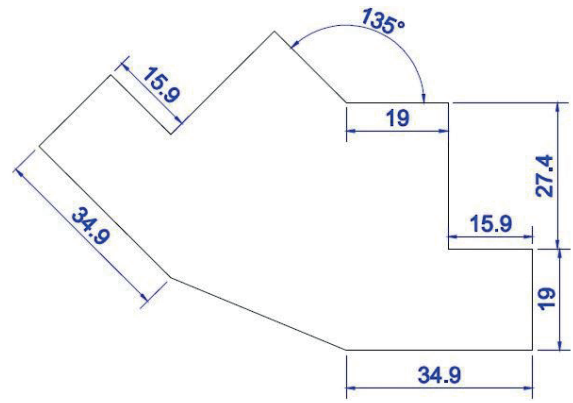

BAY POST FOR L/Z/HS FRAME

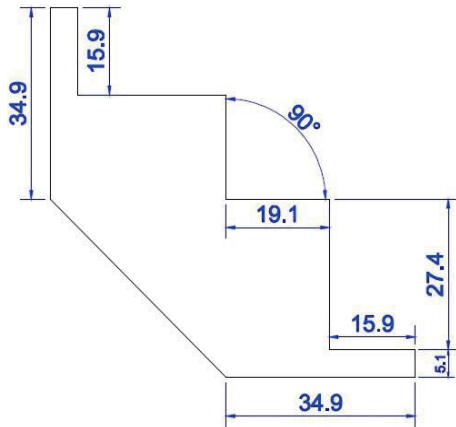

CORNER POST FOR DECO FRAME

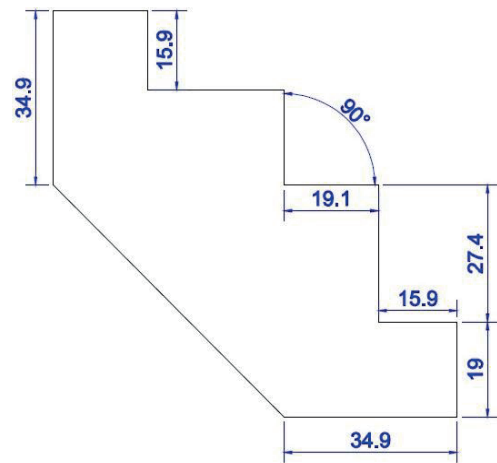

CORNER POST FOR L/Z/HS FRAME

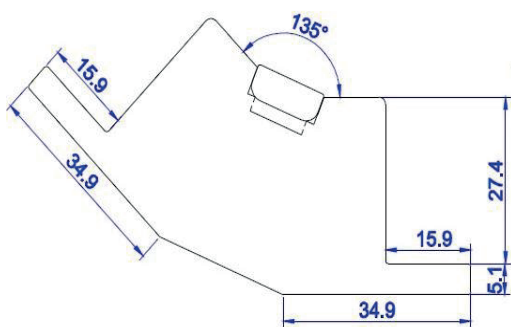

BAY POST WITH INSERT FOR DECO FRAME

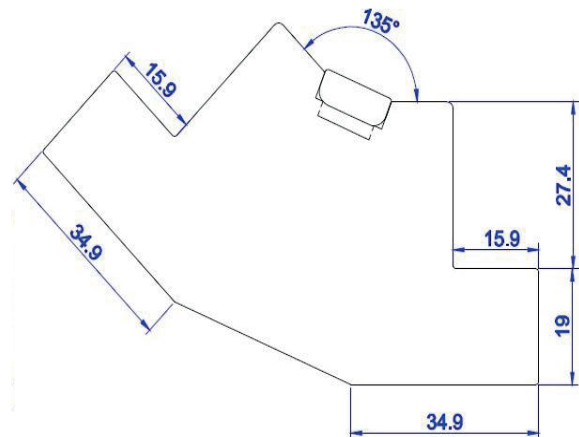

BAY POST WITH INSERT FOR L/Z/HS FRAME

POSTS

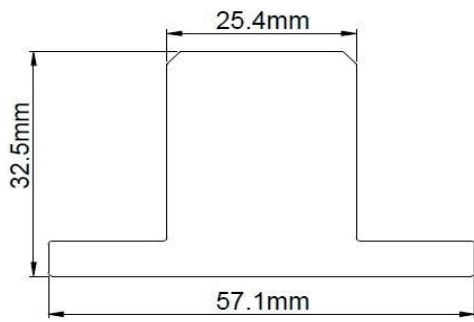

CHAMFER T POST (DECO)

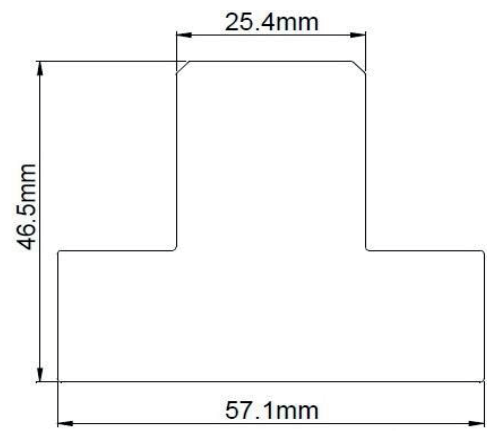

CHAMFER T POST (L/Z/HS)

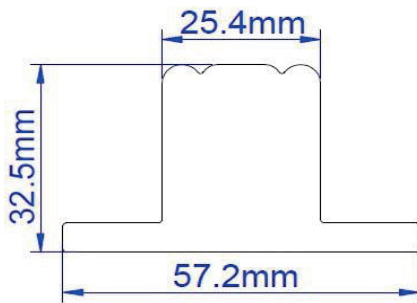

T-POST (DECO) 25MM

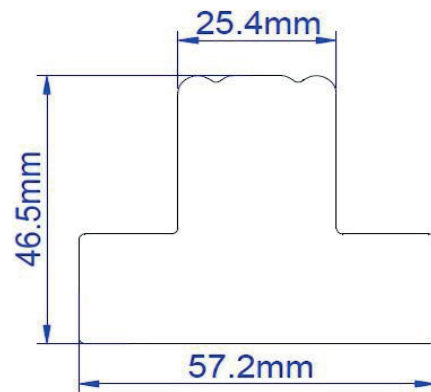

T-POST (L/Z/HS) 25MM

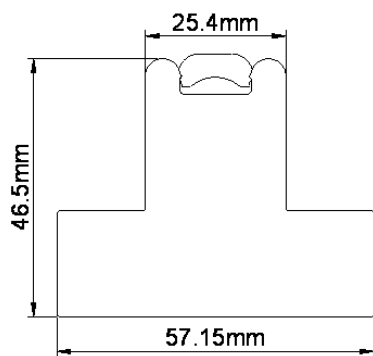

T-POST WITH INSERT 46MM

STILES - SEATTLE & GEORGIA

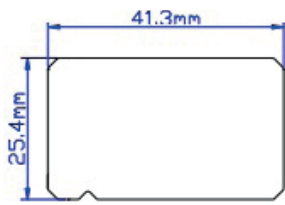

41.3MM BEADED CHAMFER
BUTT STILE

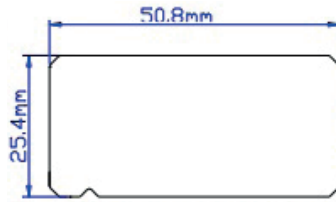

50.8MM BEADED CHAMFER
BUTT STILE

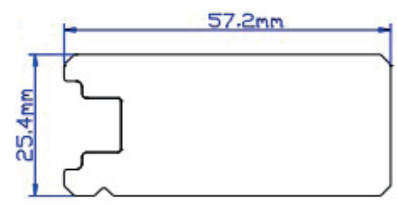

57.2MM BEADED CHAMFER
BUTT STILE

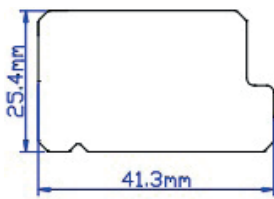

41.3MM BEADED CHAMFER
RABBET STILE

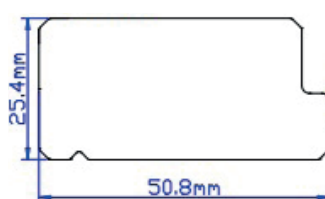

50.8MM BEADED CHAMFER
RABBET STILE

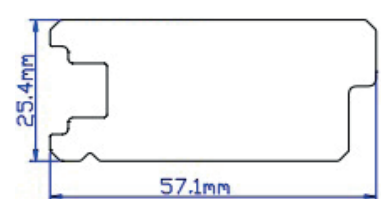

57.2MM BEADED CHAMFER
RABBET STILE

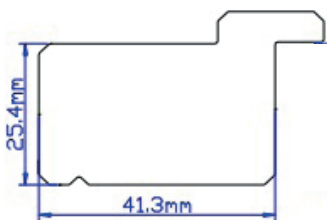

41.3MM BEADED CHAMFER
ASTRAGAL STILE

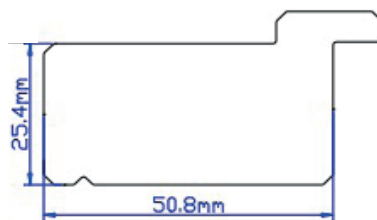

50.8MM BEADED CHAMFER
ASTRAGAL STILE

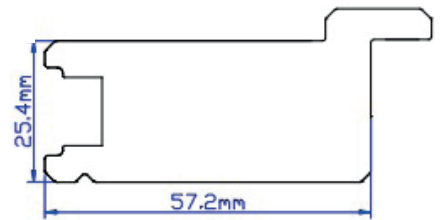

57.2MM BEADED CHAMFER
ASTRAGAL STILE



STILES - BOSTON / MONTANA

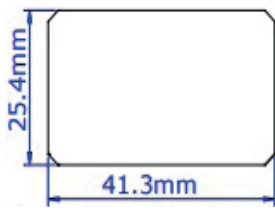

41.3MM CHAMFER BUTT STILE

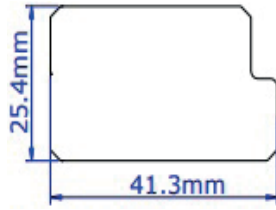

41.3MM CHAMFER RABBET STILE

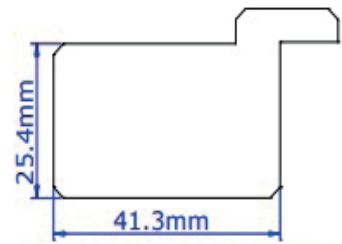

41.3MM CHAMFER
ASTRAGAL STILE

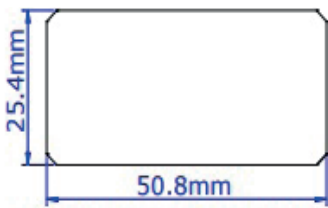

50.8MM CHAMFER BUTT STILE

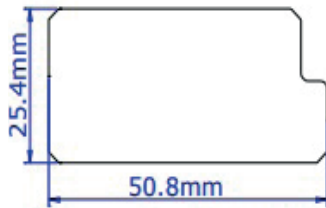

50.8MM CHAMFER RABBET STILE

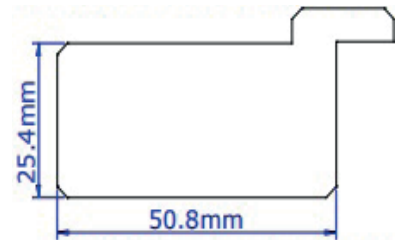

50.8MM CHAMFER
ASTRAGAL STILE

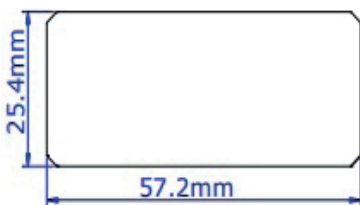

57.2MM CHAMFER BUTT STILE

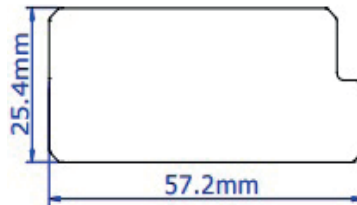

57.2MM CHAMFER RABBET STILE

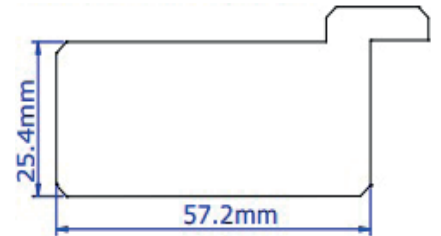

57.2MM CHAMFER
ASTRAGAL STILE

STILES - HOLLYWOOD

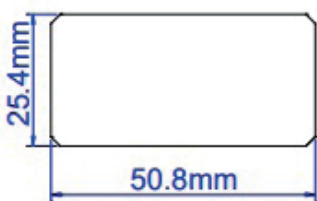

50.8MM CHAMFER BUTT STILE

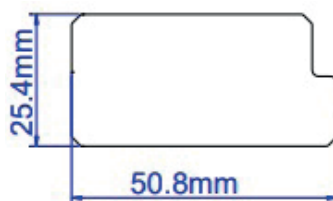

50.8MM CHAMFER RABBET STILE

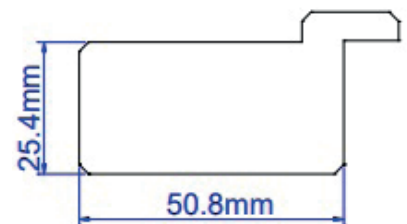

50.8MM CHAMFER
ASTRAGAL STILE

STILE POSITIONS

Please note Butt Stile is only available for single panels. For panels that measure below 220mm – Rabbet Stile will be used so that the stile does not catch against the frame for smaller panels.

Please see below for stile positioning for both Rabbet and Astragal stiles:

RABBET STILE

If choose Rabbet Stile on the order form, then the panels will be made like the following drawings.

1 PANEL : L OR R



3 PANEL : LLR/LRR



2 PANEL : LL/RR/LR

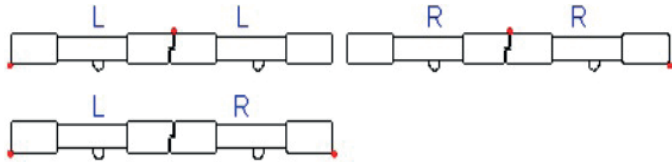

ASTRAGAL STILE

If choose Astragal Stile on the order form, then the panels will be made like the following drawings.

1 PANEL : L OR R (BOTH SIDE TO BE BUTT STILE)



4 PANEL: LLRR



2 PANEL:

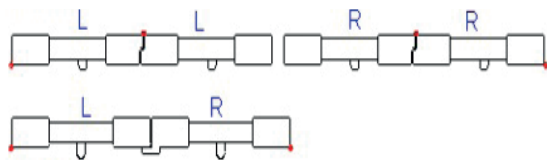

6 panels or more will be more like the following, Astragal Stile is only used where 2 panels meet without hinges.



3 PANEL:

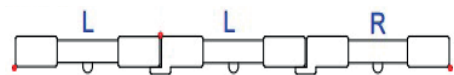

Please fill the panel configuration on the order form so that we can know where the hinges to be mounted.

BUILD OUTS

Please note that when any build out ordered exceeds 51mm. This will not be attached and will be sent separately.

- For L Frames – build out will be at the back of the L frame
- For Z frames – build out will be behind the Z frame lip
- For Deco frames – the build out will be across the full width at the back of the frame
- For corner, bay and T-posts – the build out will be at the back of the post across the full width at the back of the post

TOLERANCES

WIDTH

The shutter width can be plus or minus 2mm from the order width.

HEIGHT

The shutter height can be plus or minus 2mm from the order height.

MID RAIL LOCATION

Due to the louvre spacing, unless critical mid rail is selected, the mid rail position can vary by the tolerances stated opposite:

LOUVRE SIZE	MID RAIL TOLERANCE
47mm	+ / - 19mm
63mm	+ / - 26mm
76mm	+ / - 32mm
89mm	+ / - 38mm
114mm	+ / - 51mm

WARRANTY

The below warranty terms are applicable to all products delivered by the Supplier (Custom West)

- The colour fastness is warrantied for 3 years
- Workmanship is warrantied for 3 years
- Hardware is warrantied for 1 year
- Stainless steel hardware is warrantied for 3 year

EXTENT OF LIABILITY

The Supplier is responsible in full for maintaining the agreed quality of the products. The Supplier is responsible for the unrestricted quality assurance of the products, including the comprehensive testing of the products. The Supplier guarantees that the products are free from faults and that they comply with the agreed specifications and recognised technical standards.

REPLACEMENT OF DEFECTIVE GOODS

If the product is deemed defective or of poor quality by the supplier then a remake of the product will be supplied at the original specification free of charge. Photographic evidence must be provided showing the issues that require a remake to be provided.

CUSTOMWEST

THE SHUTTER SPECIALIST

www.customwest.co.uk